



Donatello Gold

GOLD NOTE

The Renaissance of Technology.

Thank you for your purchase of the **Donatello Gold** stereo cartridge.

Read these Operating Instructions carefully before using your **Donatello Gold** and keep it for future reference.

Before Using

1. The Stylus is very delicate. Applying excessive force to the stylus, such as pressing with a finger can break it. Handle the cartridge with the utmost care.
2. A powerful magnet is used in the cartridge. Note that carelessly bringing a steel screwdriver or other such item near the cartridge will result in it being attracted by the magnet and may result in damage to the stylus, so care must be taken.

Package Content

- Cartridge body
- Stainless Steel no-magnetic two sets of head-shell fixing 2,5mm screws
- 2mm Allen Wrench
- Owner's Manual

Method of Use

1. Mounting the cartridge on the tone arm Head-Shell using the supplied Allen Wrench and one set of the 2,5mm screws. Adjust it to the stylus position specified for the turntable system you are using mounting it properly without tilting or turning it. (See Figure 1.)

- The output terminals are colours coded for identification

as illustrated in Figure 2. Match the colors of the tone arm head-shell leads to the terminals and connect each other properly.

NOTE:

When connecting the cartridge, be sure to use the tipped leads and press them onto the terminals. Applying heat to the output terminals of the cartridge, such as in direct soldering, will cause internal damage to the cartridge, such as wire breakage.

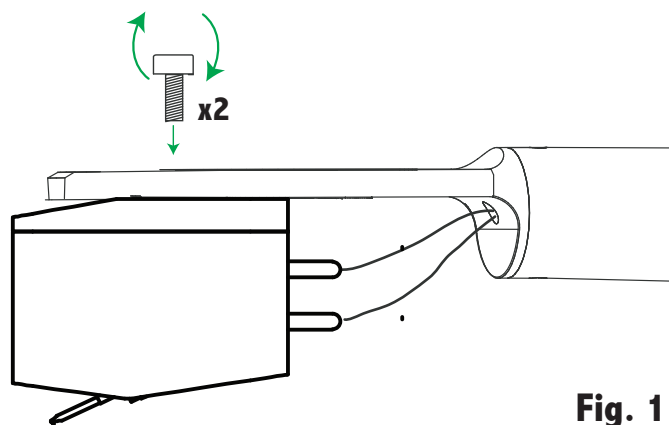

Fig. 1

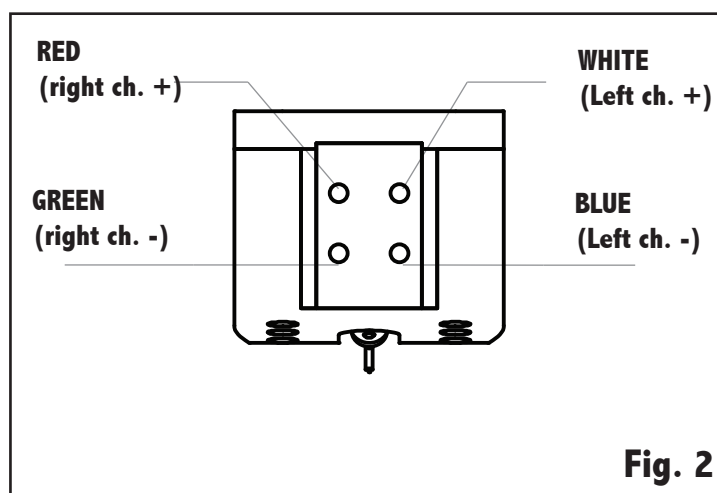

Fig. 2

The idea behind the new **Donatello MC** cartridge was to engineer the best sounding cartridge with solid machined aluminium body, light enough to be handled by every tone-arms. The results exceeded expectations

After two years of continuous research, here is Donatello: a sophisticated, computer designed body made of machined aluminium. Weighing only 7gram, it's perfectly damped and firmly blocked to help the cantilever achieve the best tracking

Donatello's ultra rigid cantilever handles a high precision Micro Elliptical diamond exclusively developed in collaboration with Adamant-Namiki and designed for top audio performance

As our flagship cartridges, Donatello's diamond tip is mechanically inserted and blocked into a long, stiffened aluminium cantilever, handled in a special titanium telescopic pipe to increase structural rigidity

There's more: like our top models, Donatello features long gold-plated pin connectors designed to connect perfectly with arm cinches, reducing energy dispersion and improving grounding for an ideal music background that will let you enjoy even the smaller details in your music

Donatello Series feature high internal impedance levels, so that they can be easily matched with any active phono preamp MM and even correctly set-up MC ones, without the need of any Step-Up transformer

Please Note: to preserve the uniqueness all **Donatello Gold** cartridges have the serial number indelibly printed in the engraved area of the top of the cartridge body.

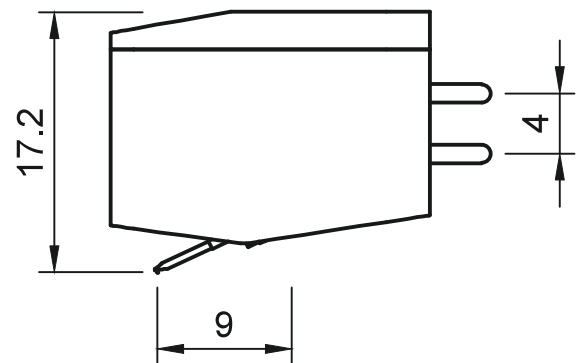
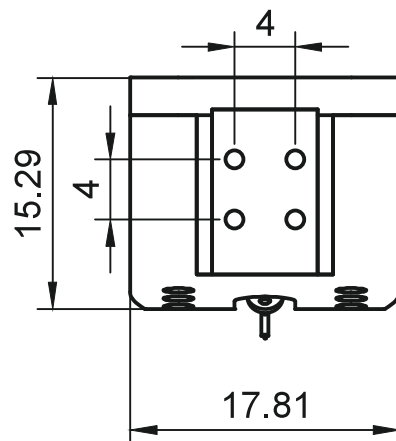

SPECIFICATIONS

Typology: MC low Output Phono Cartridge

Output level: 0.5mV

Frequency response: 10-40000Hz

Impedance: 40Ω

Suggested load: 470Ω

Compliance: 12×10⁻⁶cm/dyne

Channel separation: > 25dB

Channel balance: < 1db

Suggested tracking weight: 1.8 to 2.1g

Cantilever: Aluminum

Diamond: Micro Elliptical

Coil Wire: Copper

Magnet: Samarium-Cobalt

Mounting hole diamond distance: 9mm

Physical

Total weight: 7g

Body

solid block machined Duraluminium alloy

Color

gold body - black logo - black name

GOLD NOTE
The Renaissance of Technology.



Via della Gora, 6
Montespertoli (Florence) Italy 50025

Tel. + 39 0571 675005

Fax. + 39 0571 675013

www.goldnote.it