

Suitable for 8-10 inch in-ceiling speakers with a maximum installation depth of 185 mm!

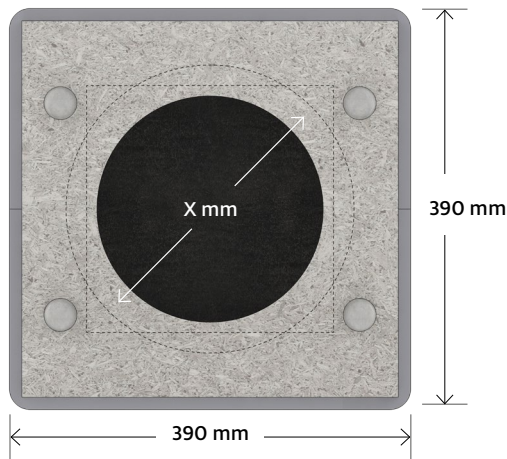

Lines show maximum possible cut-out dimension

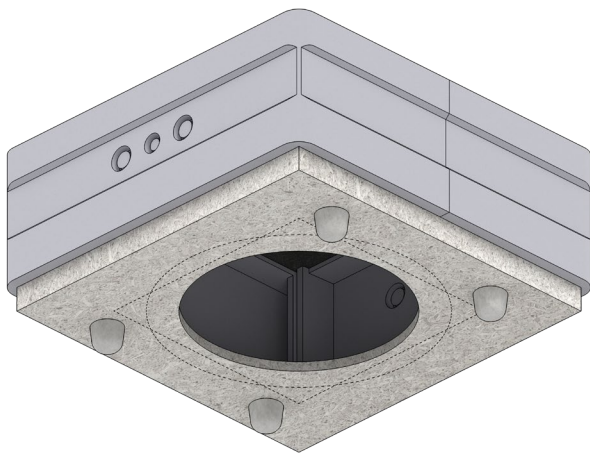
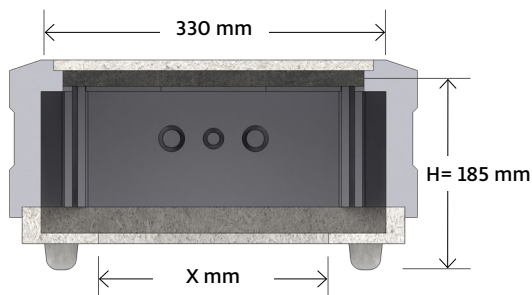
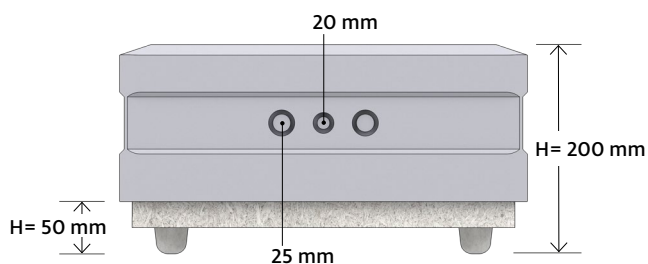

## Description

Euroboxx: backbox for concrete ceilings  
Loudspeaker-backbox consisting of EPS base body with glued-in OSB back wall cover and OSB front panel with cut-out adapter for installation in concrete ceilings.

## Features and benefits

- two side cut-outs for 20 mm + 25 mm ductwork
- low weight and high stability with excellent shock absorption
- better audio reproduction than other enclosures made of wood, sheet metal or plastic
- better air and structure-borne sound insulation than conventional in-ceiling systems
- 4 concrete feet, 50 mm height
- interior insulation: foam insulation mat 10 mm

**i** Suitable also for exposed concrete ceilings

## Scope of supply (per piece)

- 1 Euroboxx XL in EPS grey, 50 kg/m<sup>3</sup> with glued OSB cover (quartz coated)
- 1 concrete ring in EPS/PE white, 30 kg/m<sup>3</sup>, 50 mm height
- 3 steel nails 3.5 × 65 mm
- 4 aluminum nails 3.0 × 25 mm
- 2 × perforated tape
- 4 × cable ties

Type	Euroboxx XL
Dimensions	390 × 390 × 200 mm (L × W × H)
Installation depth max.	185 mm
Cut-out dimension X	circular: max. 280 mm square: 260 × 260 mm
Internal volume	16.20 l
Fire protection classification	B1
Pallet unit	54 pieces without packaging 48 pieces with packaging



Installation & Info  
<https://b-system.com/Euroboxx-qr>